



H2S-AE Hydrogen Sulfide Sensor

High Concentration



Figure 1 H2S-AE Schematic Diagram

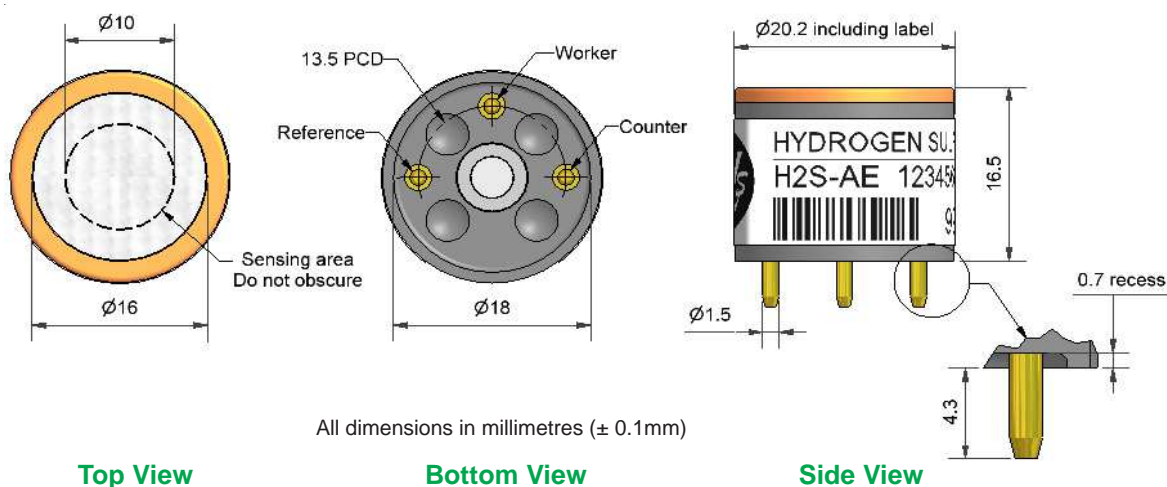

Technical Specification

PERFORMANCE	Sensitivity	nA/ppm in 400ppm H ₂ S	65 to 110
	Response time	t ₉₀ (s) from zero to 400ppm H ₂ S	< 25
	Zero current	ppm equivalent in zero air	< ± 3
	Resolution	RMS noise (ppm equivalent)	< 0.5
	Range	ppm H ₂ S limit of performance warranty	2,000
	Linearity	ppm error at full scale, linear at zero and 400ppm H ₂ S	0 to -40
	Overgas limit	maximum ppm for stable response to gas pulse	10,000
LIFETIME	Zero drift	ppm equivalent change/year in lab air	nd
	Sensitivity drift	% change/year in lab air, monthly test	nd
	Operating life	months until 80% original signal (24 month warranted)	> 24
ENVIRONMENTAL	Sensitivity @ -20°C	% (output @ -20°C/output @ 20°C) @ 20ppm	80 to 92
	Sensitivity @ 50°C	% (output @ 50°C/output @ 20°C) @ 20ppm	100 to 110
	Zero @ -20°C	ppm equivalent change from 20°C	< ± 1
	Zero @ 50°C	ppm equivalent change from 20°C	< ± 1
CROSS SENSITIVITY	NO ₂ sensitivity	% measured gas @ 10ppm	< -20
	Cl ₂ sensitivity	% measured gas @ 10ppm	< -15
	NO sensitivity	% measured gas @ 50ppm	< 20
	SO ₂ sensitivity	% measured gas @ 20ppm	< 20
	CO sensitivity	% measured gas @ 400ppm	< 4
	H ₂ sensitivity	% measured gas @ 400ppm	< 1
	C ₂ H ₄ sensitivity	% measured gas @ 400ppm	< 0.1
NH ₃ sensitivity	% measured gas @ 20ppm	< 0.1	
KEY SPECIFICATIONS	Temperature range	°C	-30 to 50
	Pressure range	kPa	80 to 120
	Humidity range	% rh continuous	15 to 90
	Storage period	months @ 3 to 20°C (stored in sealed pot)	6
	Load resistor	Ω (recommended)	10 to 47
	Weight	g	< 6



At the end of the product's life, do not dispose of any electronic sensor, component or instrument in the domestic waste, but contact the instrument manufacturer, Alphasense or its distributor for disposal instructions.

ApolloSense Ltd



H2S-AE Performance Data

Technical Specification

Figure 2 Sensitivity Temperature Dependence

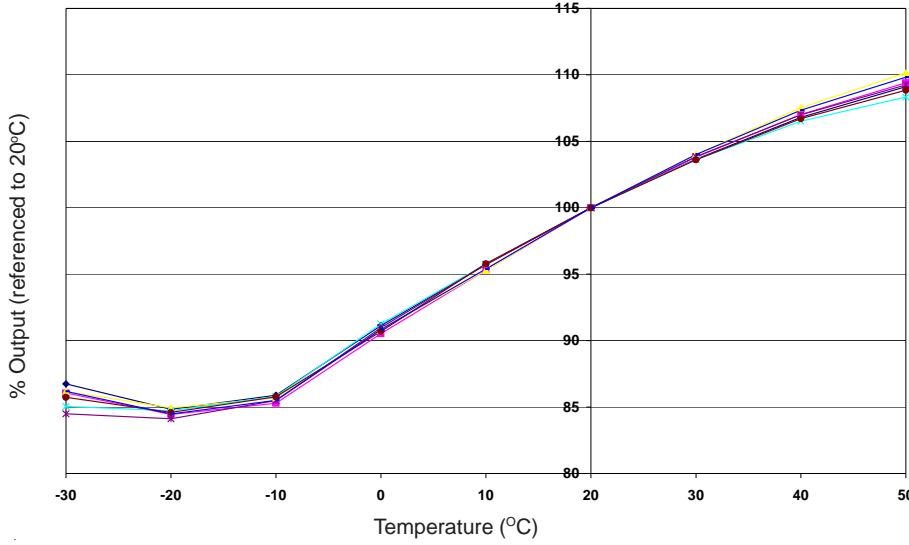

Figure 2 shows the variation of sensitivity due to changes in temperature.

This data is taken from a typical batch of sensors.

Figure 3 Zero Temperature Dependence

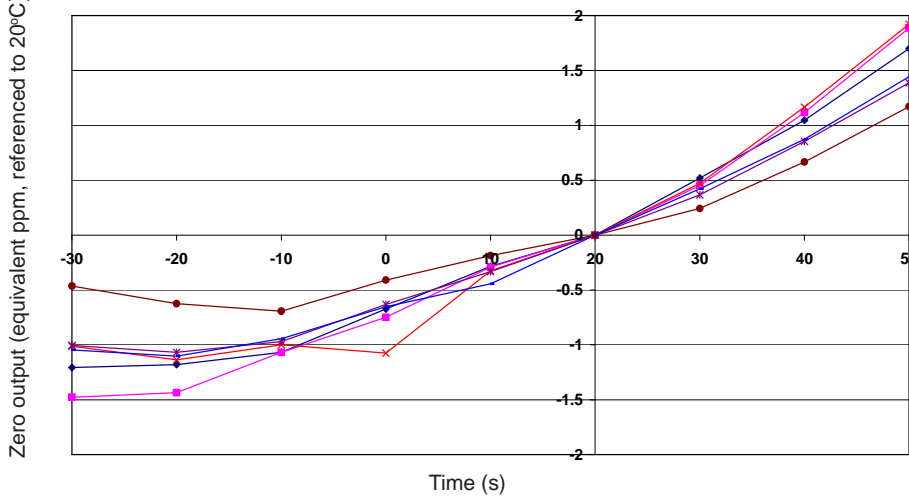

Figure 3 shows the variation in zero output caused by changes in temperature, expressed as ppm gas equivalent, referenced to zero at 20°C.

This data is taken from a typical batch of sensors.

Figure 4 Batch Repeatability

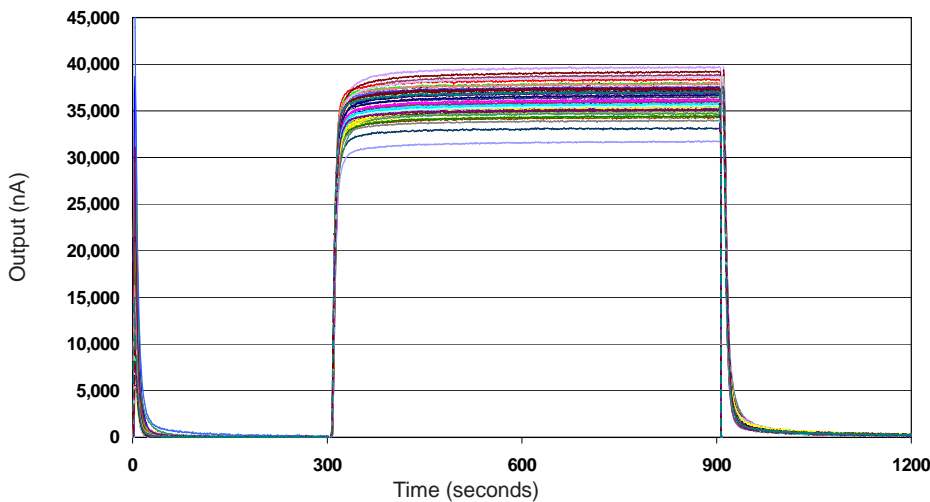

Figure 4 shows the response to 400ppm H₂S for 64 sensors. Repeatable zero, fast response and stable output are the result of good process control.

This data is taken from a typical batch of sensors.